

Owner's Manual

Orion RXB-E Kids Electric Balance Bike, FOR AGES 2-12

IMPORTANT: READ MANUAL CAREFULLY BEFORE OPERATING

We care about the safety and comfort of our customers. This manual will guide you through proper techniques in operating your Orion RXB-E balance bike.

For any additional information, please visit: OrionPowersports.com



NOTE: Manual illustrations are for demonstration purposes only. Illustrations may not reflect the exact appearance of the actual product. Specifications are subject to change without notice. Please have your product Serial Number (S/N) or a copy of your receipt before contacting us for warranty assistance and/or replacement parts.

⚠ WARNING: Riding a Electric balance bike does present potential risks and caution is required. Like any riding product, an electric balance bike has inherent hazards associated with its use (for example, falling off or riding it into a hazardous situation). When riding the balance bike, it is possible to lose control or otherwise get into dangerous situations. Both children and the adults responsible for supervising them, must recognize that if such hazards occur, a rider can be seriously injured or die even when using safety equipment and other precautions. RIDE AT YOUR OWN RISK.

Contents

These pages give an overview of the contents of your owner's manual

Quick Reference	1
Introduction	2
A Few Words About Safety	4
Electric Balancer Pre-Riding Safety	5
<i>Before Riding</i>	6
<i>Safety Equipment</i>	9
Message To Riders	10
Loading, Accessories & Modifications	11
Safety Labels	13
Important Information	14
Operating and Riding the Electric Balancer	15
<i>Electric Balance Bike Components</i>	15
<i>Power Mode</i>	17
<i>How to Change the Modes of the Balancer</i>	19
<i>Safely Approaching or Re-Mounting the Bike</i>	21
<i>Loading and Unloading bike into a Vehicle</i>	21
<i>Pre-Ride Inspection and Checklist</i>	22
<i>After Riding</i>	23
<i>Charging</i>	24
Repair and Maintenance	25
<i>Tools Included in the Kit</i>	25
<i>Test Brake</i>	26
<i>Adjust Brake</i>	26
<i>Battery Removal</i>	27
<i>Battery Installation</i>	30
<i>Battery Disposal</i>	33
Troubleshooting Guide	34
Cleaning and Appearance Care	35
Controller Diagram	37
Specification	39
Spare Part Catalogue	41
Parts Finder	47
Warranty	48
Disclaimer	49

Quick Reference

Model Version	12 in	16 in	20 in
Grips	Universal MX		
Handlebars	Fat Bar 1" Clamp (25.4mm) x 520mm		
Battery	24v, 5.2Ah	36v, 5.2Ah	48v, 5.2Ah
Charger	1.2-1.8Ah		
Tires and Tubes	12" x 2.25-2.7	16" x 2.1-2.4	20" x 1.95



Introduction

Congratulations on the purchase of your new Electric Balance Bike! With proper assembly and maintenance, it will offer you years of enjoyable riding!

IMPORTANT:

Carefully read and follow this manual (and any other materials included with this bike) before riding. Please retain this manual for future use. If this bike was purchased for a child, it is the responsibility of the purchaser to verify the bike has been properly assembled, and that the user has been properly trained and instructed in use of the bike.

This manual is provided to assist you and is not intended to be a comprehensive manual covering all aspects of maintaining and repairing your bicycle. The bicycle you have purchased is a complex piece of equipment that must be properly assembled and maintained in order to be ridden safely.

The user or consumer assumes all risk of personal injuries, damage, or failure of the bicycle or system and all other losses or damages to themselves and others and to any property arising as a result of using the bicycle.

DO NOT DISASSEMBLE, MODIFY OR REPLACE ELECTRICAL PARTS.

If you need to change any parts, please consult one of our authorized dealers or contact customer service for additional help.

NOTE: YOUR INSURANCE POLICIES MAY NOT PROVIDE COVERAGE FOR ACCIDENTS INVOLVING THE USE OF THIS BICYCLE. TO DETERMINE IF COVERAGE IS PROVIDED YOU SHOULD CONTACT YOUR INSURANCE COMPANY OR AGENT.

Introduction

 DANGER: Failure to properly assemble and maintain your bicycle could result in serious injury or death to the rider.

This manual contains important safety, performance and service information. The purpose of this Owner's Manual is to help you use your bike safely in the manner it is intended and allow you to enjoy the benefits it offers for many years to come. Please read it before you take the first ride on your new bike, and keep it for reference. If you have any questions or do not understand something, take responsibility for your safety and contact Orion RXB-E customer service at 817-350-4520 or info@orionpowersports.com

ALWAYS WEAR A PROPERLY FITTED HELMET WHEN YOU RIDE YOUR BICYCLE. DO NOT RIDE AT NIGHT. AVOID RIDING IN WET CONDITIONS.

A Few Words About Safety

Your safety, and the safety of others, is very important and operating this electric balance bike safely is an important responsibility.



You could be **SERIOUSLY HURT** if you don't follow instructions.



You could be **HURT** if you don't follow instructions.

WARNING



Always use an approved helmet & protective gear

Never use on public roads

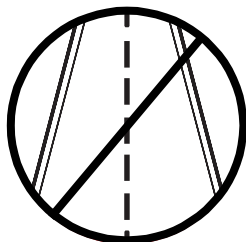

Never carry passengers

This section presents some of the most important information and recommendations to help you ride your electric balancer safely.

Please take a few moments to read these pages. This section also includes a special message for parents and location information for the safety labels on your electric balancer.

Electric Balancer Pre-Riding Safety

⚠ CAUTION: For your safety you must carefully read this manual and follow its instructions. Your bicycle may come with additional instruction sheets that cover features unique to your bike. Please ensure that you read and become familiar with their contents and retain them with this manual for future reference. Remember bicycles, in most areas, are subject to the same laws, rules, and regulations as motor vehicles.

Always wear a Certified helmet when riding your bike. Learn

and follow local and state traffic use laws.

Any major service or adjustments on your bike not covered in this manual should be carried out by a professional bicycle mechanic. If you wish to make adjustments yourself, this manual contains important tips on how to do it.

⚠ CAUTION: Any adjustments you make are entirely at your own risk. Do NOT use your bike for freestyle and stunt riding, jumping or competitive events. Do not ride your bike when any part is damaged or not working properly. You must, for your safety and the safety of other users, consult a professional bicycle mechanic for any questions on repairs or maintenance.

⚠ WARNING: As with all mechanical components, the bicycle is subjected to wear and high stresses. Different materials and components react to wear or stress fatigue in different ways. As your bicycle ages, you should inspect it more frequently to look for deformed, cracked, bent, or loose components. Such conditions may lead to sudden failure. This may possibly cause injuries to the rider. If something is cracked or broken, do not ride until repairs have been made.

Electric Balancer Pre-Riding Safety

BEFORE RIDING

1. **⚠ WARNING—ON AND OFF ROAD CONDITIONS:** The condition of the riding surface is very important to your safety. If the surface is wet, or has sand, leaves, small rocks or other loose debris on the surface where you plan to ride, carefully decrease the speed of the bicycle and ride with extra caution. It will take a longer time and more distance to stop. Apply the brakes sooner and with less force. Always apply the rear brake first allowing time and distance for it to take effect. Then follow by cautiously applying the front brake, in order to maintain control of the bicycle. Rapid front brake application first may cause a front pitch over or fall. Learn to use your brakes properly under controlled conditions until you learn proper braking under all road conditions.
2. **NOTICE:** State and federal regulations require a full set of reflectors. Some state and local laws may require that your bike be equipped with a warning device, such as a horn or bell and most states require a light. The manufacturer and many legal authorities DO NOT approve or encourage riding at night. Vision is quite limited at dawn, dusk and at night for bike riders, motorists and by-standers. If you must ride at night, take extra precautions, use front and rear lights, wear flashers on your arms, wear light-colored clothing, and plan your route to ride in well lit areas avoiding heavy traffic areas.
3. **NOTE:** Always wear shoes when riding a bicycle and avoid loose fitting clothes. Wear a cuff band or trouser clip to keep pants or other loose clothing from getting caught in the chain wheel. Long sleeves, long pants, gloves, eye protection, a DOT/CPSC approved helmet, elbow and knee pads are recommended. Helmet use is required by law in many states and is always a good idea for your safety.

Electric Balancer Pre-Riding Safety

4. **⚠ CAUTION: WET WEATHER WARNING:** Check your brakes frequently. The ability to stop is critical to your safety. Roads are slippery in wet weather so avoid sharp turns and allow more distance for stopping. Brakes become less efficient when wet. Leaves, loose gravel and other debris on the road can also lengthen stopping distance. If at all possible, do not ride in wet weather. Vision and control are impaired, creating a greater risk of accidents and injury.
5. **⚠ CAUTION:** A bicycle rider's best defense against accidents is to be alert to road conditions and traffic in the area. Do not wear anything that restricts your vision or your hearing.
6. When riding, **ALWAYS WEAR A APPROVED BIKE HELMET**. It may save your life.
7. Obey all traffic regulations. Most traffic regulations apply to bike riders as well as automobile operators. Observe all state and local traffic regulations, signs and signals. Check with your local police station on bicycle licensing and inspection, and where it is legal to ride your bike.
8. **ON AND OFF ROAD OPERATION:** Avoid the following road hazards: drain grates, pot holes, ruts, soft road edges, gravel, leaves (especially when they are wet), uneven pavement, railroad crossings, manhole covers, curbs, speed bumps, puddles, and debris as all have an effect on your riding and may result in loss of control. Adjust your speed and the way you use your brakes if you must ride in such areas.
9. If any components become loose while riding, **(STOP!!)** immediately and tighten, or bring to a mechanic for repair.

Electric Balancer Pre-Riding Safety

TO AVOID INJURY, THIS PRODUCT MUST BE PROPERLY ASSEMBLED BEFORE USE. WE STRONGLY RECOMMEND THAT YOU REVIEW THE COMPLETE ASSEMBLY GUIDE AND PERFORM CHECKS SPECIFIED IN THE OWNER'S MANUAL BEFORE RIDING.

Just a minute spent before each ride can significantly improve your safety and the enjoyment of your ride. **EACH TIME** before you ride make a habit of performing the following safety checks:

- Stand in front of the bicycle facing rearward and hold the front wheel securely between your legs. Try to twist the handlebar and verify that they do not move. Then pull the handlebars up, trying to lift the bike. There should be no movement.
- Try to push the front wheel from side to side and confirm that it feels tight and will not wobble. Lift the front wheel up by the handlebars and strike the wheel downward with the heel of your hand to confirm that it is securely attached to the wheel. Spin the front wheel and confirm that it does not wobble or contact the fork or brake pads.
- Try to lift/push down on and twist the seat to confirm it is tight.
- Look at the connection of the pedals to the crank arm. You should not see pedal screw threads and the pedal should feel firm and be parallel to the ground.
- Apply your brake(s) and make sure they feel firm to the touch, and then spin the wheel(s). Apply the brakes. The brakes should stop the wheel(s).
- Check to be sure that the fenders and accessories (if equipped) are firmly attached and will not contact any moving parts. Make sure all reflectors are in position and not broken.

Now, put on your **BICYCLE SAFETY HELMET** and enjoy your ride. Your safety is well worth just a minute. Also, be sure to read and follow the warnings and instructions in this manual

Electric Balancer Pre-Riding Safety

SAFETY EQUIPMENT

Orion RXB-E promotes the use of safety equipment during the use of your electric balance bike; the following list is an advisory guideline of the equipment that should be obtained before using your electric balancer for the first time, and to be used for every ride regardless of experience and skill level.

HELMET



A helmet is the most important piece of protective equipment and should be worn at all times the electric balancer is being ridden.

Ensure the helmet fits the operator snugly, is securely fastened and provides good, all-round visibility. A poorly-fitting or loose helmet can become dislodged in an incident and then offer no protection at all.

EYE PROTECTION

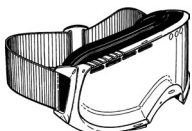

Recommended to prevent eye injuries and prevent branches, bugs, dust or sand hitting your face and distracting you. Sunglasses are unlikely to provide adequate physical protection.

GLOVES



Sturdy footwear is recommended

FOOTWEAR



Arms and legs should be covered to reduce abrasions to the body, even in hot weather. Trousers should be close-fitting and in good condition.

CLOTHING



Message To Riders

Your safety is very important to Orion RXB-E. That's why we urge you to read this message before riding this electric balancer. You can help prevent accidents by making good decisions about if, when, and how you ride this electric balancer.

THINGS TO CONSIDER WHEN RIDING

The first decision you'll need to make is whether you're ready to ride. Riding readiness varies widely from one person to another, and age and size are not the only factors.

PHYSICAL ABILITY

An important consideration is that riders must be big enough to hold the electric balancer up, get on, and comfortably sit on the seat with both feet touching the ground. They should also be able to easily reach and

work the brakes, throttle, and all other controls.

If you decide that you're ready to safely operate this electric balancer, make sure you carefully read and understand the owner's manual before riding. Also be sure that you have a helmet and other appropriate riding equipment, and always wears it when Operating the electric balancer or sitting on it.

SAFE AND RESPONSIBLE RIDING

When you put safety first, you can enjoy more peace of mind, and you can enjoy more hours of safe off-road riding.

Loading, Accessories & Modifications

Orion RXB-E designed a rider-only electric balance bike. It was not designed to carry a passenger or cargo. A passenger or cargo could interfere with your ability to move around to maintain your balance and control of the electric balancer.

In addition, exceeding the weight limits or carrying an unbalanced load can seriously affect your bike's handling, braking, and stability. Adding accessories or making modifications that change this electric balance bike design and performance can also make it unsafe. Also, the weight of any accessories will reduce the maximum load the electric balancer can carry

We recommend that you do not carry any cargo on this electric balancer.



ACCESSORIES & MODIFICATION

Modifying your electric balance bike or using non-Orion RXB-E accessories can make your electric balance bike unsafe.

Loading, Accessories & Modifications

ACCESSORIES

We strongly recommend that you use only Orion RXB-E Genuine Parts and Accessories that have been specifically designed or approved and tested for your electric balance bike. Because Orion RXB-E cannot test all other accessories, you must be personally responsible for proper selection, installation, and use of non-Orion RXB-E accessories. Check with your dealer for assistance and always follow this guideline:

Make sure the accessory:

- Does not reduce ground clearance and lean angle
- Limit steering travel
- Alter your riding position
- Interfere with operating any controls

MODIFICATIONS

We strongly advise you not to remove any original equipment or modify your electric balance bike in any way that would change its design or operation. Such changes could seriously impair your electric balancer handling, stability, and braking, making it unsafe to ride.

We also advise you not to make any modifications or remove any equipment that would make the electric balance bike illegal in your area.

Safety Labels

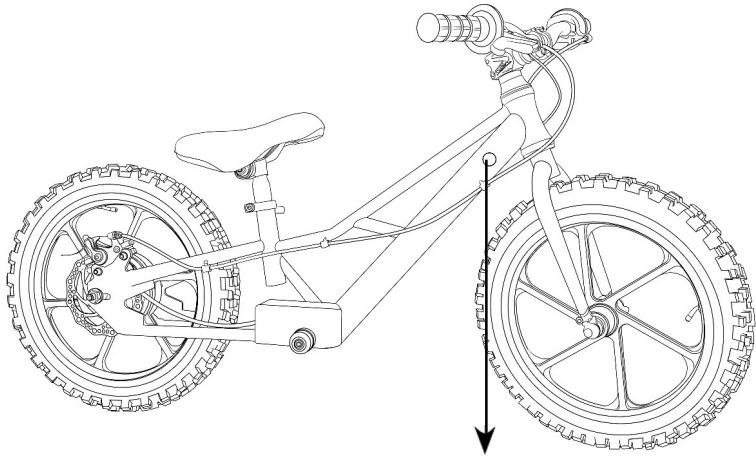

⚠ WARNING

- Always wear protective equipment such as helmet, knee pads, elbow pads and shoes.
- Do not ride as night, in areas of low visibility.
 - Max rider weight may not exceed 120 lbs / 65 kgs; Weight in excess of this amount may damage the bike.
 - For riders 3 years old and up only.
 - To reduce the risk of injury, adult supervision is required. Never use in roadways, near motor vehicles, on or near steep inclines or steps, swimming pools or other bodies of water; always wear shoes, and never allow more than one rider.
 - Traffic can be fatal, do not ride on streets, around cars, or sidewalks.

Important Information

FRONT WHEEL INSTALLATION:

The front axel is located in the tool kit. Please take a picture of it before you install it. The washers and spacers are in the correct order. See pics below.

INSTALL THE FRONT AXLE IN THE ORDER SHOWN ABOVE

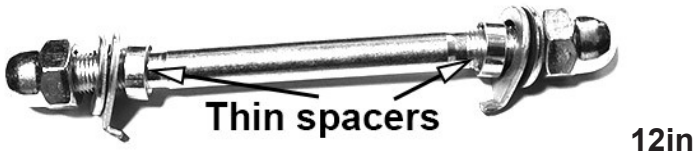

16in

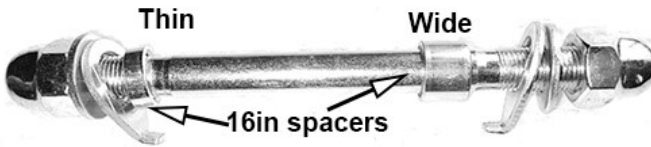

HANDLE BAR ASSEMBLY



Attach the handlebars as shown. There are 4 screws to assemble or remove the handlebar. The Power S/W should be at a 60-90 degree angle, pointing straight up. This allows the small riders to twist the throttle all the way open.

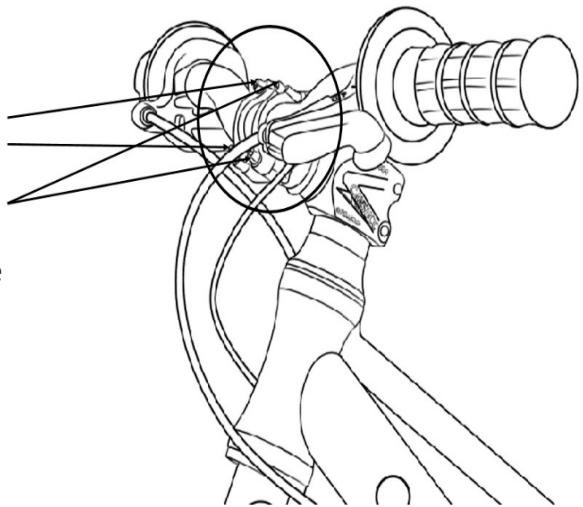

Operating and Riding the Electric Balancer

Please familiarize yourself with the components below.



Operating and Riding the Electric Balancer

1. Frame	10. Front axle	19. Brake Disc
2. Handlebar	11. Charge Port	
3. Handlebar grip	12. Footrest	
4. Brake lever	13. Seat	
5. Throttle	14. Seat Post	
6. Front fork	15. Seat Clamp	
7. Stem	16. Hub Motor	
8. Head Clamp	17. Rear Axle Nuts	
9. Front Wheel	18. Brake Caliper	

Operating and Riding the Electric Balancer

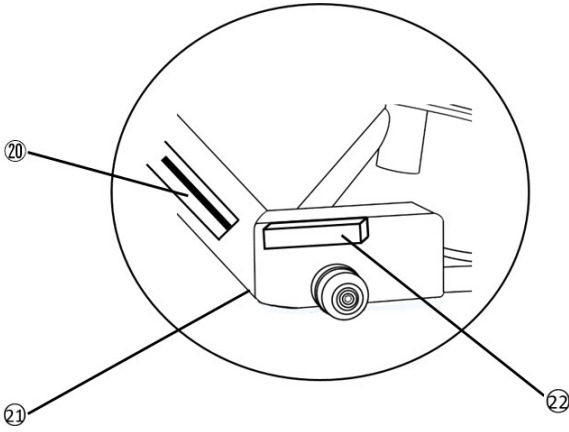

- 20. Battery
- 21. Controller Box Cover Screw
- 22. Controller

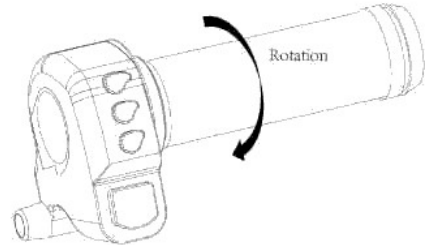
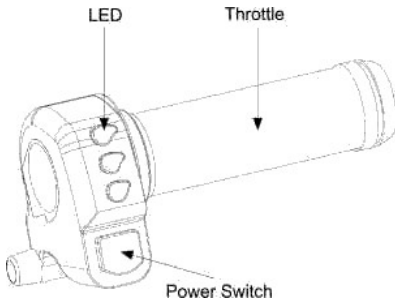

Operating and Riding the Electric Balancer

IMPORTANT INFORMATION

Non-powered training: We recommend that you teach your child how to balance the bike first before you add power. They should be proficient at kicking and balancing the bike before turning the power switch on. There are many videos on YouTube that can teach them how to kick and balance a bike.

POWER MODE

The 12in comes in the lowest speed settings and 50% power. We programmed the beginner mode so that the balancer does not move too fast and you can briskly walk next to your child while training. The throttle is not very responsive and has a delay built in and takes a few seconds to start moving (1.5 sec). If you are unsure the bike is working simply lift the rear wheel, twist the throttle and spin the rear wheel forward. Once they kick or you push them, the bike will start to move and will slowly gain speed as it goes. This is a safety feature built in so that the Balancer does not start too fast and scare them. In speed setting 3, the throttle delay goes away.

We leave the speed cap off so that you can adjust the speeds quickly to your child's skill level. After you have chosen a safe setting for your child's skill level, we recommend you cover the switch (cover is in the tool bag) so they cannot change the mode and go faster.

The illustration on the next page shows you the different positions of the speed switch located on the bottom of the frame. As mentioned above, the 12in comes with 50 % power, kick-start and the slowest speed setting (1-3 mph). To change to 100 %power, full torque, non-kick mode - please refer to the next page.

⚠ WARNING: It is recommended that once you change to full-power mode, you monitor your child and make sure that they can operate the bike safely. We recommend that you change 1 setting at a time as follows:

SPEED SWITCH LOCATION

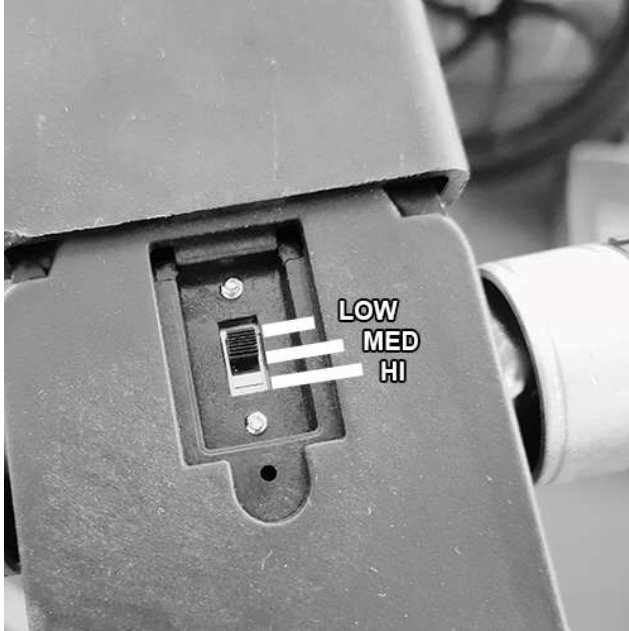

DO NOT ADD FULL POWER AND NON-KICK START AT THE SAME TIME.

Changing Modes:

After your child is proficient with the bike and you feel comfortable with their riding ability you can start changing modes. Instructions are on the next page.

The first change we recommend you make is to remove the kick-start (12in only) and switch back to the slowest speed. After they get comfortable with the twist-n-go you can change speeds until they are in the highest speed. Once they are driving around in the fastest speed you can change to 100% power (make sure you move the speed sw back to the lowest speed after you add 100% power).

Operating and Riding the Electric Balancer

In full power mode and the highest speed setting, the twist throttle delay time is reduced to 0.1 seconds (instant throttle response), so make sure your child has enough open space in front of them to safely ride and will not crash into any obstacles.

16in comes with 50% power, non-kick mode and the slowest speed setting. Follow the same instructions as above for the 12in. See the next page for instructions on how to release the full potential of the Electric Balance bike.

Operating and Riding the Electric Balancer

HOW TO CHANGE THE MODES:

- Remove the 4 screws for the plastic rock protector as shown.

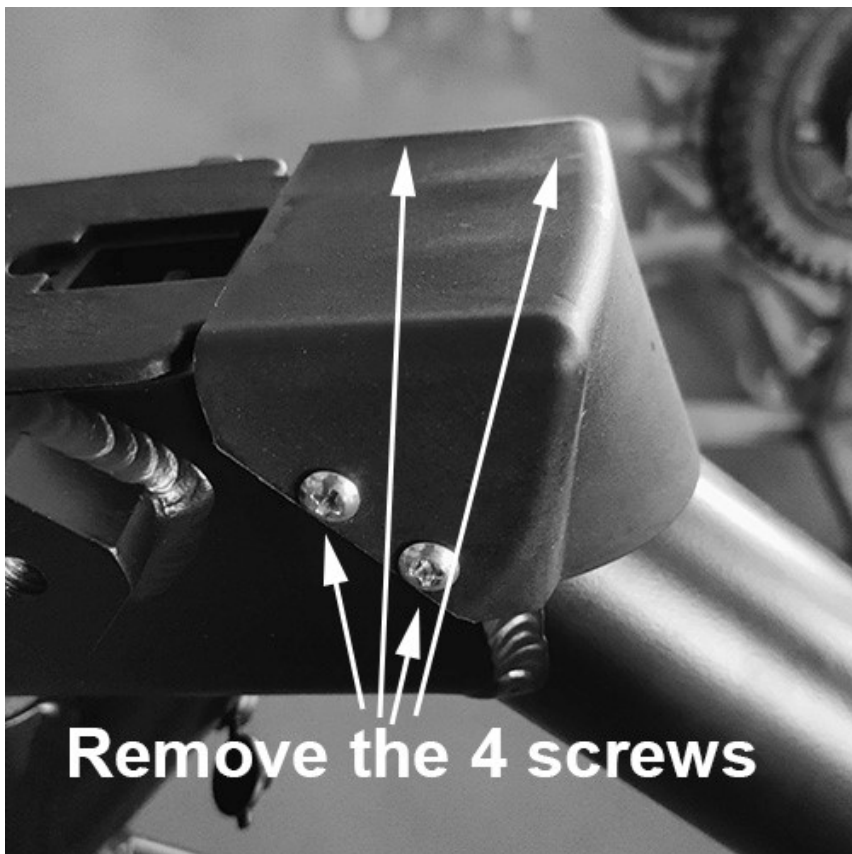

Operating and Riding the Electric Balancer

⚠ WARNING: DO NOT PRY THE COVER FROM THE SIDES OR THE REAR, THERE ARE LOCKING TABS ON THE REAR OF THE COVER AND YOU WILL BREAK THEM OFF. PLEASE READ THESE INSTRUCTIONS CAREFULLY.

Please pay attention when you remove the cover. The speed switch is connected to the cover. Once you pry the cover off you can unplug it.

The cover opens from the front (round part) and will require you to pry it open as shown in the pic below. A screwdriver or anything flat will work.



STOP!!!! After you remove the cover take a picture of the wires and how they are arranged.

Operating and Riding the Electric Balancer

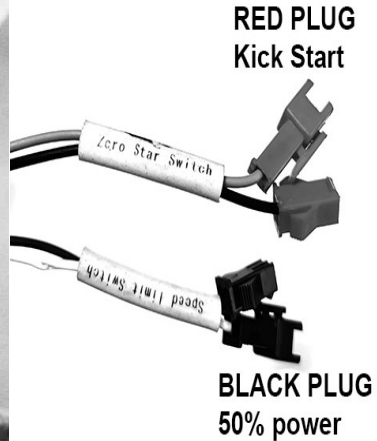
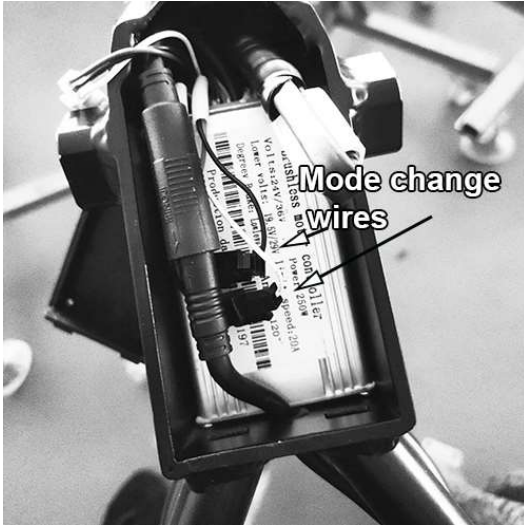

To locate the wires, we wrapped the wires with a white tube and zip-tied the group together. The words ‘Zero Start Switch’-KSM, and “Speed Limit ” 50%-100% power are on each set of the wires. See pic above.

- 50-100% power mode: Locate the solid BLACK AND WHITE wires with a black connector and white tube that says “power limit switch” and unplug it. This will give you 100% power.
- KSM mode: Locate the solid BLACK AND LIGHT BLUE wires with the red connector and unplug it. This will change the Balance Bike to NON-Kick mode (12in only). 16in has this function however we do not connect it. If you want this function on your 16in bike then connect the red connector together.

Operating and Riding the Electric Balancer

See wiring diagram below for reference.

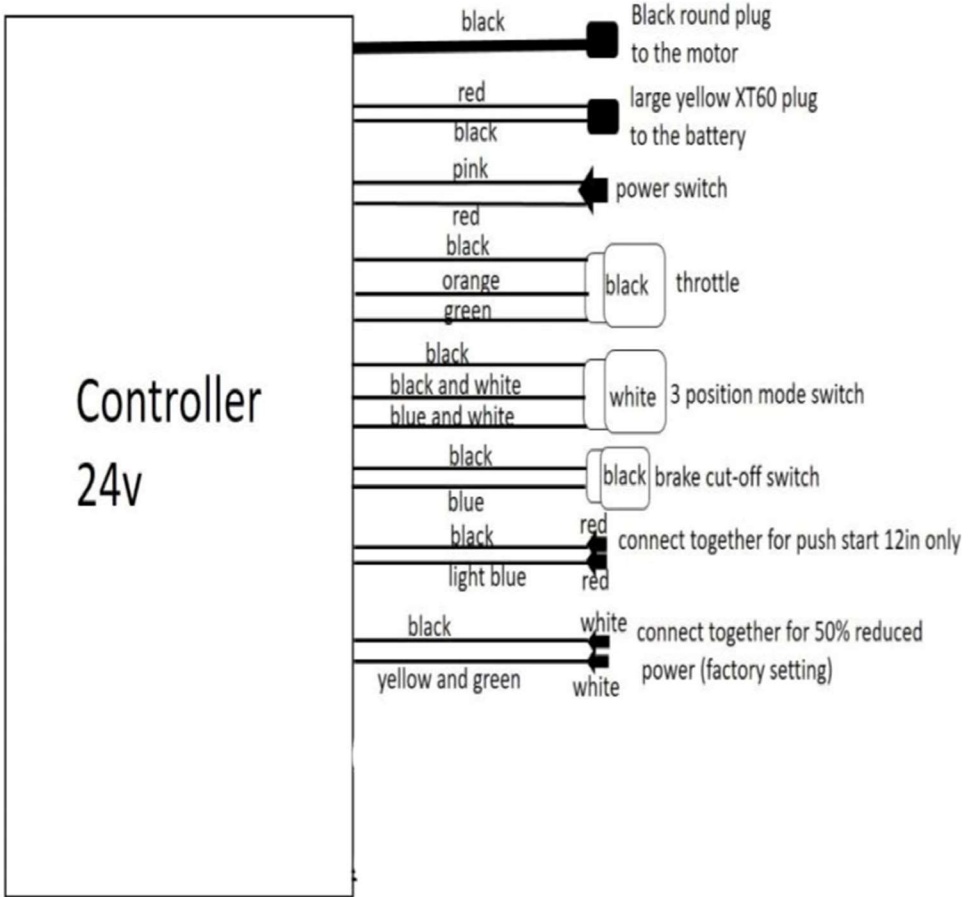

⚠ CAUTION: Running with full speed will decrease the running time and drain the battery faster. Operating at full speed will make the battery, controller and motor get hot. Excessive riding in this mode will decrease the life of the components.

Operating and Riding the Electric Balancer

SAFELY APPROACHING OR RE-MOUNTING THE Orion RXB-E ELECTRIC BALANCE

- Teach children to approach the bike with caution; before use or while standing back up if knocked over.
- Ensure the power switch is turned off because if they try and lift the bike with the throttle the bike will take off and could drag them.
- Ensure all wheels/tires have stopped rotating or moving.
- Inspect for any obvious damage.
- Perform a Pre-Ride Inspection
- Have the rider mount the bike from the brake lever side. Pull the brake lever with the left hand a kick your leg over. The brake lever has a cut out switch built into it so the bike cannot move if the power is on and someone twists the throttle.
- Please press the power switch to the 'ON' position.
- Carefully resume riding your bike.

LOADING AND UNLOADING ORION RXB-E ELECTRIC BALANCER INTO A VEHICLE

- Ensure the power switch is turned off.
- Load into a vehicle for transport.
- After unloading, ensure that Power Switch is still switched off.
- Perform Pre-Ride Inspection.

Operating and Riding the Electric Balancer

CHECK AND MAINTAIN

Before every use, check that the bike is in proper working order. The bike should be maintained and repaired in accordance with the manufacturer's specifications, using only the manufacturer's authorized replacement parts, and should not be modified from the manufacturer's original design and configuration.

PRE-RIDE INSPECTION AND CHECKLIST

Power Switch: Ensure that the Power Switch is turned off during the Pre-Ride Inspection and remains 'OFF' until the rider is sitting on the seat, both hands gripping the handlebars, pulling the brake lever, and both feet flat on the ground.

Throttle: Ensure the Power Switch is turned off. Check that the throttle rotates freely, and the return spring returns the throttle back to 'ZERO' position from the 'FULL'. Ensure there are no cracks, dirt or visible damage that may cause the throttle to stick in the open position.

Brake: Check brake for proper function. When you squeeze the lever, the brake should provide positive braking action. Slight rubbing is normal.

Tires: Inspect the tires for excess wear. Regularly check the pressure and inflate as per tire specifications.

Frame, Fork, Stem and Handlebars: Check for cracks and loose hardware. Broken components are rare, however it is possible to break parts after you have crashed. It is important to make a regular habit of inspecting your Balancer every time you ride it.

Hardware/Loose Parts: Check all your hardware such as nuts, bolts, cables, fasteners, etc., to ensure that they are secure. There should not be any unusual rattles or sounds from loose parts or broken components. If the unit is damaged, do not ride it. Reference 'Warnings' listed in this manual.

Laws and Regulations: Check and obey local laws or regulations prior

Operating and Riding the Electric Balancer

to riding.

Operating and Riding the Electric Balancer

Adjust the height of the seat.

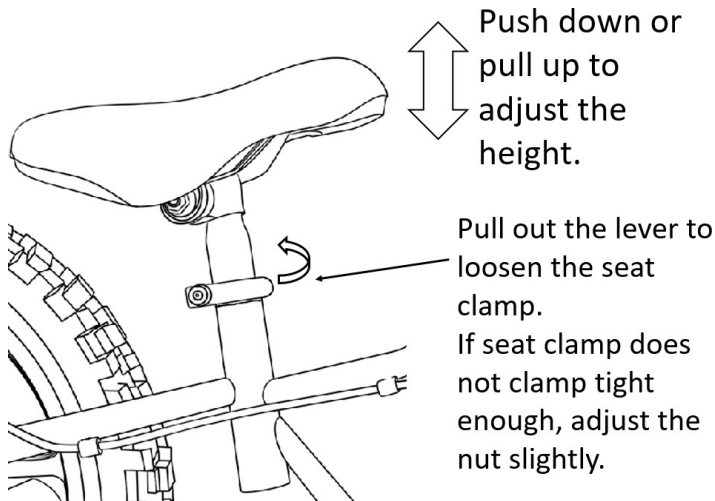

AFTER RIDING

- Check the battery capacity with the power on.
- It is recommended to charge the battery when the red light comes on or when the bike stops.
- If the yellow light is on... keep going. If the rider is finished riding and the yellow light is on, connect the charger.
- Charging after each use is a good idea.
- Disconnect charger from the bike after it is fully charged. Unplug the charger from the wall.

Operating and Riding the Electric Balancer

CHARGING

- Insert the charger into the 110V/220V wall socket; the light on the charger will turn green.
- Insert the plug from the charger into the charger port on the frame of the Balancer (you might see a small spark or hear a pop, this is normal).
- The light on the charger will turn RED, indicating that the battery is being charged. If the light does not turn RED, then the battery is fully charged, the charger has a problem, or both. Please see the 'Troubleshooting' section for further instructions or contact your dealer.
- The light will turn GREEN indicating that the battery is fully charged.
- Make sure that the bike is charged under a dry and cool conditions.

Approx. Charging Times:

5.2Ah... 2-3.5 hours, if completely drained

⚠ CAUTION: Leaving the bike in direct sunlight for a long time (5-8 hours) will harm the battery or even cause it to explode.

Repair and Maintenance

TOOLS INCLUDED IN THE KIT

- 2.5, 4, 5, 6 and 8 mm Allen Wrench
- 14,16,19 mm socket or open spanner

Turn power switch to “OFF” position, allow the bike to cool before beginning repair or maintenance:

- Read instructions.
- Ensure the power switch to the “OFF” position.
- Ensure bike has had adequate time to cool (up to 30 minutes)
- Secure the bike for repair or maintenance.
- Exercise caution around exposed parts.
- Contact Orion RXB-E customer service if unsure about any repair or maintenance.

REPLACEMENT PARTS

For the complete selection of replacement parts go to xrtmoto.com

Repair and Maintenance

TEST BRAKE

- Squeeze brake and hold.
- Push the bike forward. The rear wheel should not spin if the brake is adjusted properly.
- If rear wheel spins when pushing forward or the lever engages prematurely, refer to “Adjust Brake”

ADJUST BRAKE

- To adjust brake cable:
 - Twist brake lever adjust in or out, $\frac{1}{4}$ to $\frac{1}{2}$ turn at a time, until desired brake adjustment is attained.
 - If the brake still needs further adjustment, proceed to step 2.
- Determine if brake cable loose or brake rotor is dragged on brake pad or not:
 - Loosen brake hubs barrel adjuster.
 - Adjust brake hub adjuster in or out until the desired brake adjustment is attained.
 - Lock brake hub barrel adjuster.
 - Perform final adjustment of tension in brake cable with brake lever barrel adjuster.
 - Repeat “Test Brake” section above.

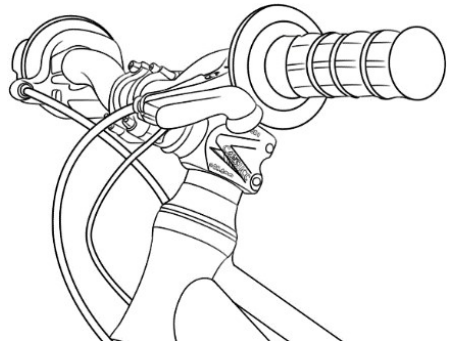
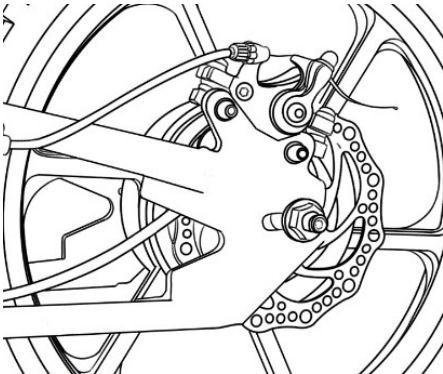

⚠ WARNING: Test and practice breaking in an open area free from obstacles, in a straight line, until the child is familiar with the brake function.

Repair and Maintenance

BATTERY REMOVAL

Step one: Remove the cover (see page 21)

Step two: After you have removed the cover, take some pictures. Carefully pull out the wires of the controllers and only unplug the three pin throttle wires (org, green, blk), 2 pin power switch (pink and black), 2 pin Brake switch (blue, black), yellow XR60 connector for battery. Do not disconnect the large black round plug or the wires that are zip tied together. Pull out the controller and let it hang off to the side (pic below). If you accidentally unplug the large round black connector, make sure you line up the arrows when you plug it back in together.

Repair and Maintenance

Step three: Once you have removed the controller you will see the charge wire, cut the shrink tube off and un-plug it.

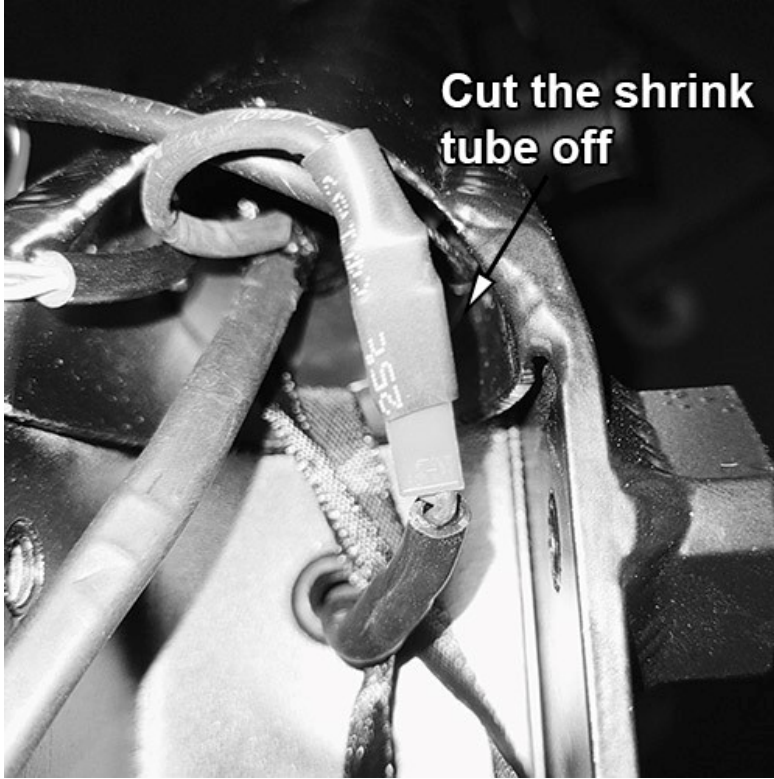

Step four: Un-wrap the disconnect the big yellow plug (XT-60)

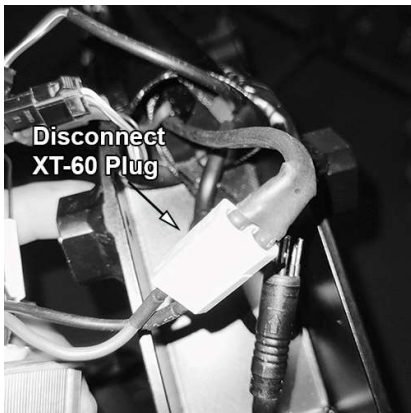

Repair and Maintenance

Step five: Find the cloth strap inside the controller box that is attached to the battery (see pic below). Slowly pull on the cloth strap; you might have to pull a bit hard to slide the battery out. If the battery does not want to come out the tube might be out of round. Check to see tube is damaged.

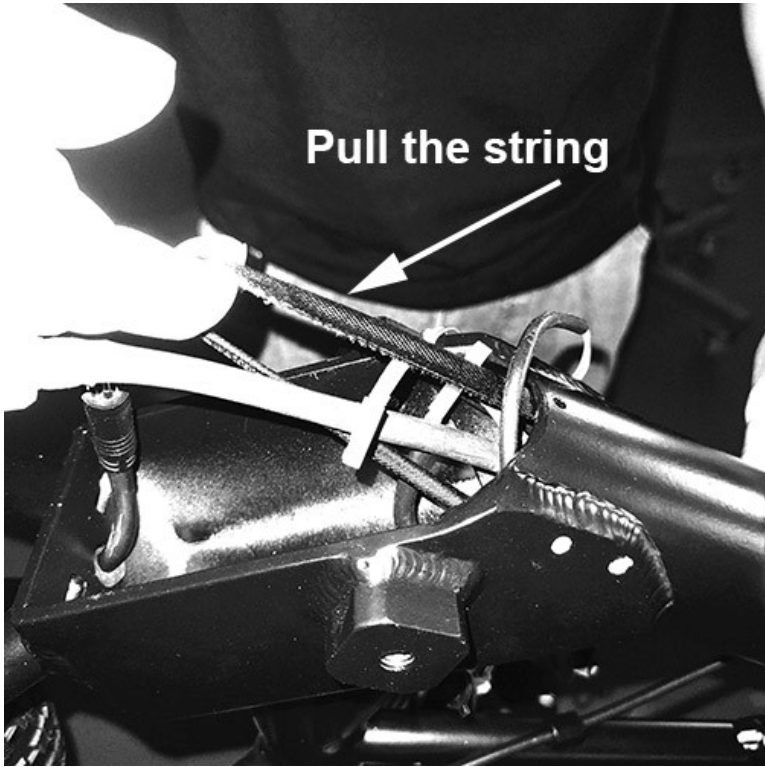

Repair and Maintenance

BATTERY INSTALLATION

Install the battery in reverse order. Below are instructions just in case you forgot.

Step one: Look inside the tube and make sure the throttle and brake wires are not crossed. Lay the wires as shown in the pic below and insert the battery.

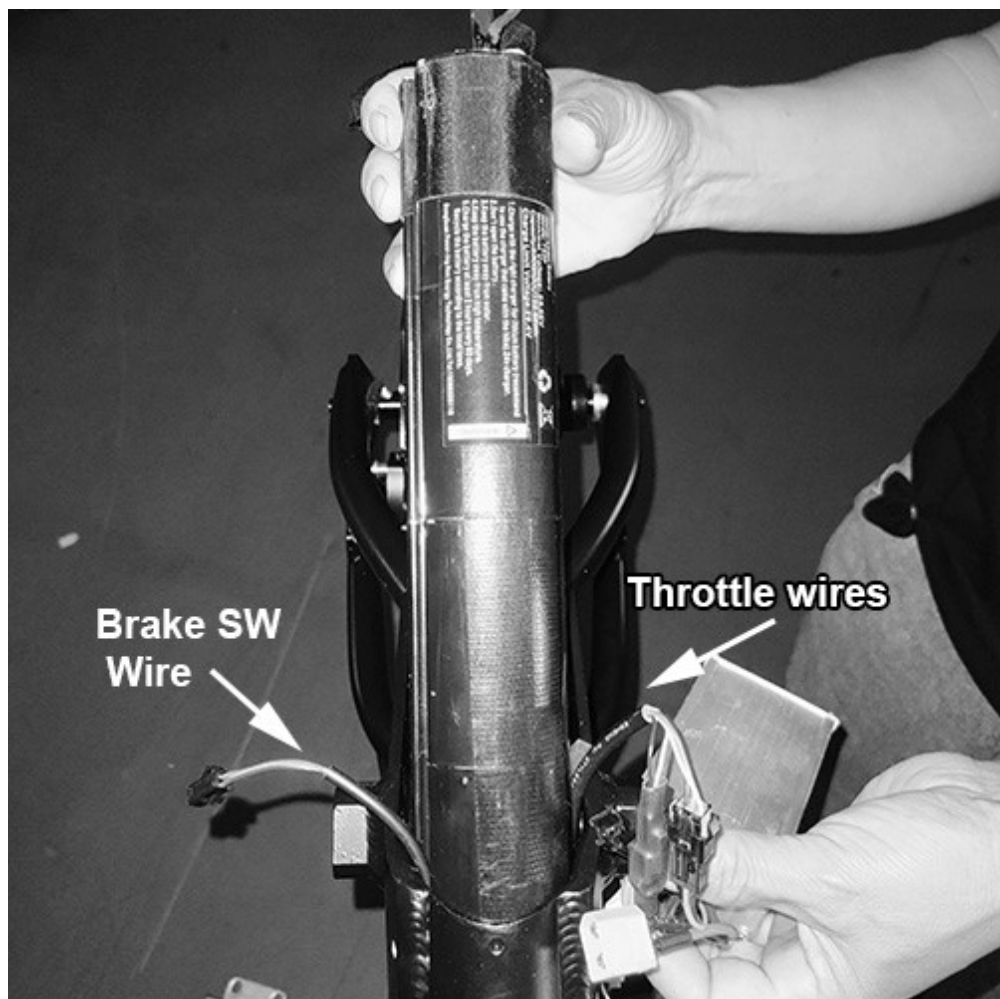

When you are finished it should look like the pic below. Leave the throttle and brake wire hanging out so you can connect them to the controller.

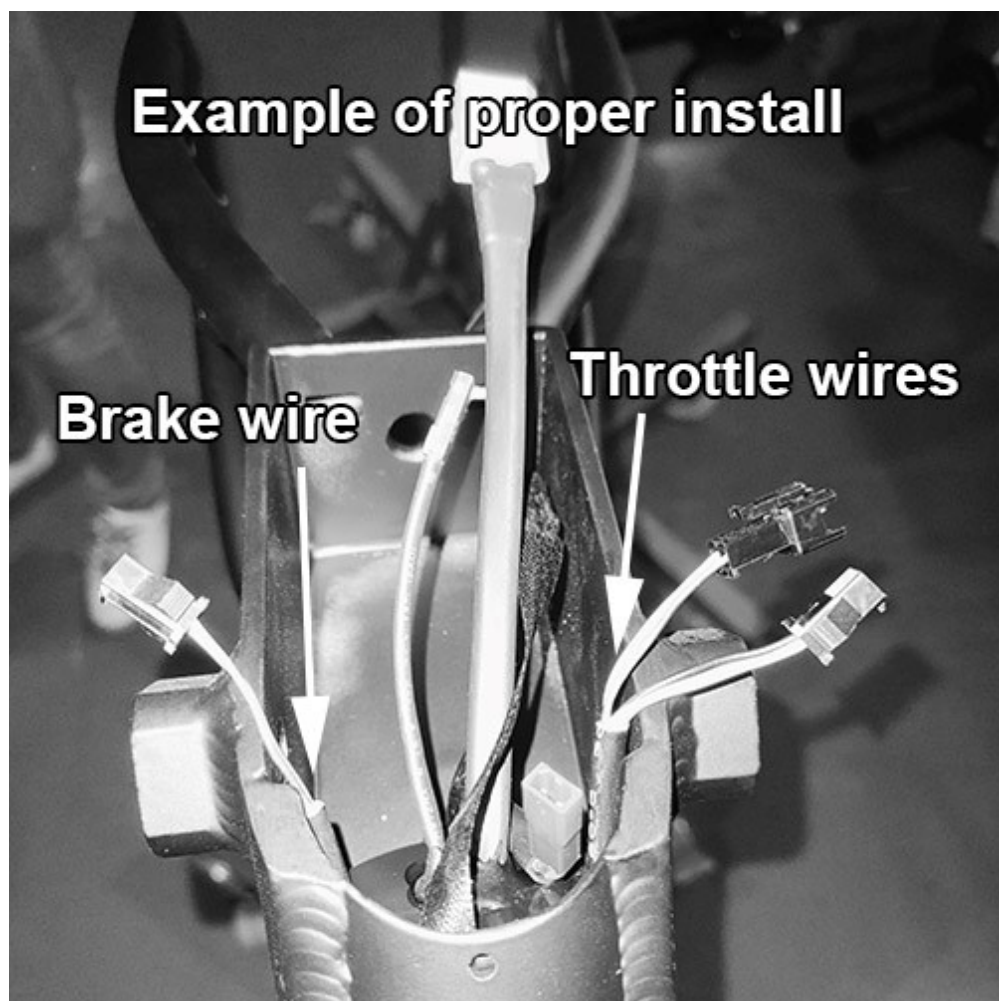

Step Two: Locate the charge port connector and plug it in. CAUTION!!! The connector can only be connected one way. See pic below. Align the slot and push firmly together.

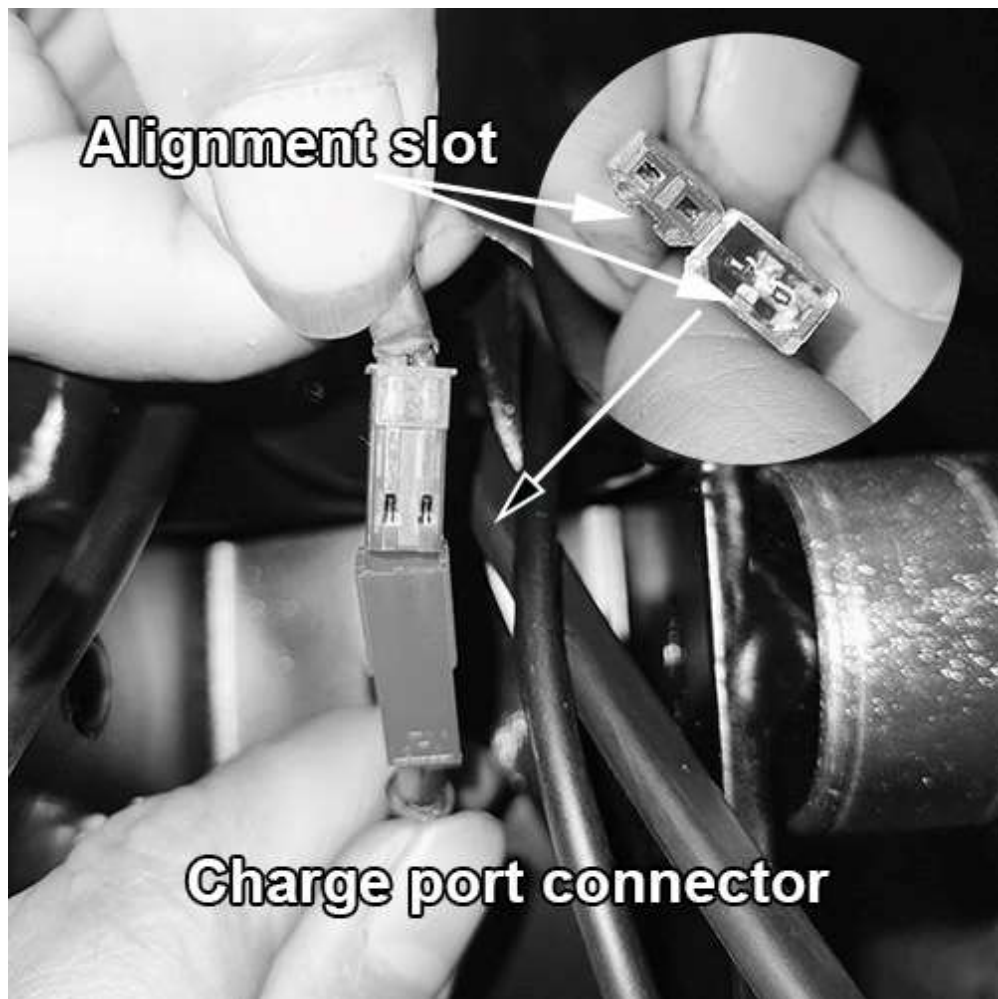

Repair and Maintenance

Step three: Install the controller back first



Push the controller into the box. Make sure the charging wire does not get smashed.



Repair and Maintenance

Plug in the XT-60 connector and wrap the wire protector around it. Tuck all the wires in and plug in the speed switch. When you are done it should look like the pic below.



Repair and Maintenance

Cleaning and Appearance Care

Troubleshooting Guide

Make sure the battery is fully charged or replaced before performing any trouble shooting ONLY to be performed by an adult.

PROBLEM	POSSIBLE CAUSE	SOLUTION
Power switch does not work or light flickers when pushing the sw	Faulty sw or bad connection Battery not fully charged	Power switch is not good. Replace the sw or throttle Verify the battery is fully charged
	Wire harness connection, faulty switch, bad controller	Follow the throttle wire down until it enters the frame, remove the rubber plug and carefully pull on the wire until the connector comes out. Unplug the connector and see if the wires have corrosion, clean the pins and reconnect. Remove the controller box cover and locate the solid dark blue and black wires. Un-plug it and pluck it back in, press the switch – same result... Unplug the connector and connect a voltmeter (ohm function) to red and blue wires that go to the switch and depress the switch. You should see the meter go to 0. No charge-switch is bad. If the meter went to 0 then you have a bad controller.
Stopped working while riding it	Loose battery or wire connection(s)	Recharge or replace battery
	Power switch faulty	Contact your local ORION RXB-E authorized service center for diagnosis and repair
	Throttle faulty	
	Motor or electrical system damage	
Rider weight/ Terrain too steep	Do not exceed the weight limit of 120lb (65kg), ride on flat terrain	
Short run time/runs slow	Battery not fully charged	Verify the battery is fully charged
	Old or damaged battery	Replace battery

Cleaning and Appearance Care

	Tire is not properly inflated	Inflate tires to the recommended pressure on tire sidewall. Replace tube if you are unable to maintain pressure.
--	-------------------------------	--

GENERAL RECOMMENDATIONS

- To clean your bike, you may use:
 - Water
 - A mild, neutral detergent and water
 - A mild spray and wipe cleaner/polisher
 - A mild spray and rinse cleaner/degreaser and water
- Avoid products that contain harsh detergents or chemical solvents that could damage the metal, paint, or plastic on your bike.
- If your electric bike is still warm from recent operation, give it time to cool off.
- We recommend the use of a garden hose to wash your electric balancer. High-pressure washers (like those at coin-operated car washes) can damage certain parts of your electric balancer.

NOTE: High-pressure water (or air) can damage certain parts on the bike.

WASHING YOUR BIKE WITH A MILD DETERGENT

Cleaning and Appearance Care

1. Rinse your electric balancer thoroughly with cool water to remove loose dirt.
2. Fill a bucket with cool water. Mix in a mild, neutral detergent, such as dish washing liquid or a product made especially for washing.

Cleaning and Appearance Care

3. Wash your electric balancer with a sponge or a soft towel. As you wash, check for heavy grime. If necessary, use a mild cleaner/degreaser to re- move the grime.
4. After washing, rinse your electric balancer thoroughly with plenty of clean water to remove any residue.
5. Dry your electric balancer with a chamois or a soft towel. Leaving water on the surface to air dry can cause dulling and water spots. As you dry, inspect for chips and scratches.
6. As a precaution, ride at a slow speed and apply the brakes several times. This will help dry the brakes and restore normal braking performance.

Controller Diagram

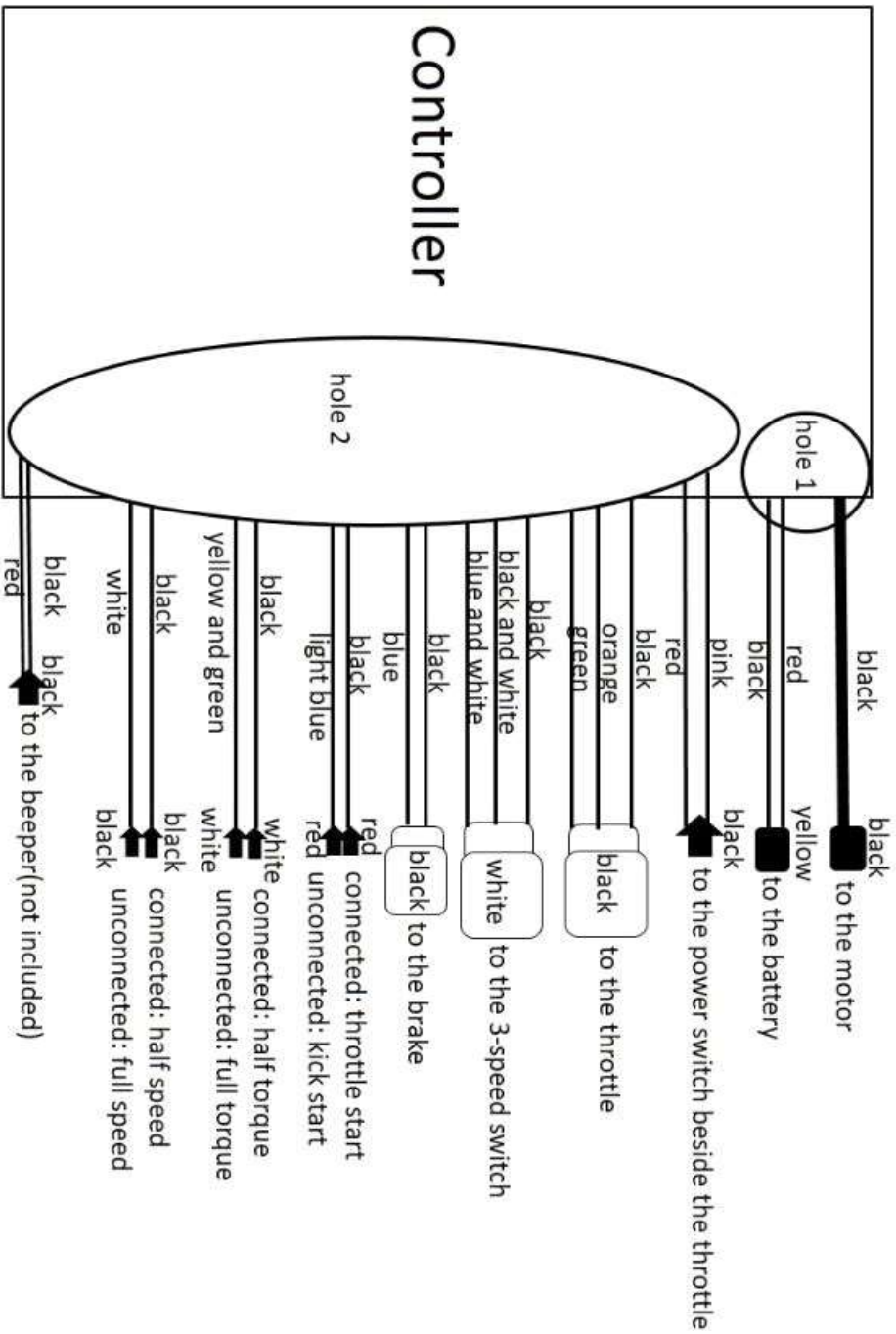

Controller Diagram

FUNCTION	WIRE COLOR	WIRE VOLTAGE REFERENCE
Connect to Battery	Red	24V
	Black	Negative
Connect to Motor	Yellow 1.5MM	When motor running, 12v. Stop 0v
	Green 1.5MM	
	Blue 1.5MM	
	Orange 0.3MM	5v with Power ON
	Yellow 0.3MM	When motor running, 12v. Stop 0v
	Green 0.3MM	
	Blue 0.3MM	
	White 0.3MM	Exchange from 0 to 5v when running
Black 0.3MM	Negative	
Connect to Power Switch	Pink	24v
	Red	Will have 24v when PWR SW is ON
Connect to Throttle	Black	Negative
	Orange	4.3v
	Green	Will have 0.8v when at 0 throttle position and go to 3.5v at full throttle
Connect to Mode Switch. White 3p connector	Black and White	5v when not switched to GND
	Black	Negative
	Blue and White	5v when not switched to GND
Connect to Brake Cut-Off	Black	Negative
	Blue	Has 5v without a brake. Goes to 0v when brake
Connect together for KSM, kick start. Red 2p connector	Black	Negative
	Light Blue	Has 5v when not connected to GND
Connect together for 50% power. Black Connector	Black	Negative
	White	Has 5v when not connected to GND
Connect together for 20% reduce torque	Black	Negative
	Yellow/Green	Has 5v when not connected to GND
Connect to Beeper (removed)	Black	Negative
	Black and Red	5v

Specifications

RXB-E 12

ENGINE AND TRANSMISSION

Engine	250w Brushless
Battery	Li 24v 5.2A-3c
Speed Mode	6 Speed (3 x 50% power + 3 x 100% power)
KSM	Kick start (Must kick or push the bike to engage the motor)
Running Time	2 Hours
Charge Time	2-4 Hours
Final Drive	Rear hub, Direct Drive Motor (No Chain)

SUSPENSION, BRAKES AND WHEELS

Suspension Front	N/A
Suspension Rear	N/A
Brakes Front	N/A
Brakes Rear	Disc Brake
Wheel & Tire Front	12-2.125
Wheel & Tire Rear	12-2.125

DIMENSIONS AND WEIGHT

Wheelbase	690mm 27"
Seat Height	250mm + 100mm 10" + 4"
Weight (N.W/G.W)	13.6/15Kg 24/27 Lbs
Max Load	75 Kg / 165 Lbs
Product Packing Size	870x222x440mm .1m3

Specifications

RXB-E 16

ENGINE AND TRANSMISSION

Engine	350w Brushless
Battery	Li 36v 5.2A-3c
Speed Mode	6 Speed (3 x 50% + 3 x 100%)
KSM	Kick start (Must kick or push the bike to engage the motor)
Running Time	2 Hours
Charge Time	2-4 Hours
Final Drive	Rear Hub, Gear Drive Motor (No Chain)

SUSPENSION, BRAKES AND WHEELS

Suspension Front	N/A
Suspension Rear	N/A
Brakes Front	N/A
Brakes Rear	Disc Brake
Wheel & Tire Front	16-2.125
Wheel & Tire Rear	16-2.125

DIMENSIONS AND WEIGHT

Wheelbase	780mm 31"
Seat Height	480mm + 100mm 19" + 4"
Weight (N.W/G.W)	14.6/16 Kg 24/27 Lbs
Max Load	75 Kg / 165 Lbs
Product Packing Size	1010x220x505mm .1m3

Parts Finder

Finding Parts at our website

Websites

<https://www.orionrx.com>

Warranty

ORION RXB-E LIMITED WARRANTY

Warranty registration should be online within 7 days of purchase.

ORION warrants the product to be free from material and manufacturing defects from date of purchase as described below

- Frame – One (1) Year
- Electrical system components, including battery and charger – 90 days.

This Limited Warranty will be void if the product is not used in accordance with the owner's manual, such as:

- Damage in an accident, crash or loss of control incident
- Used in a manner other than for recreation.
- Poorly or incorrectly maintained.
- Used in a manner in which this product was not specifically designed.
- Failure to follow owner's manual instructions or warnings
- Electronics or battery exposed to water.
- Modified in any way.
- Damaged by unauthorized service or parts.
- Used for commercial purposes.

This Limited Warranty does not cover any damage, failure or loss caused by improper assembly, maintenance, or storage.

ORION is not liable for incidental or consequential loss or damage due directly or indirectly to the use or misuse of this product.

For your records, save your original sales receipt with this manual and write the serial number below. Serial number is located on the rear hub motor.

Serial Number (located on the hub motor): _____

Date Purchased: _____

Purchased From: _____

Disclaimer

ORION will not be held liable under any circumstance for incidental or consequential loss or damage or injury, due direct or indirect use of this product, including any malfunction or defect.

Adult guardians assume all responsibilities associated with the use of these products by minors. It is not suitable for handicapped persons or persons with limited mental or physical capacities. Customers understand that the use of these products can cause injury or death to themselves or others. To reduce the risks of any such injuries we strongly recommend the use of safety equipment such as approved helmets and kneepads.

The Buyer holds our company and its agents and affiliates harmless from any liability arising out of or relating to the use or ownership of any product. Purchaser fully accepts responsibility and releases the seller for all and any personal injuries, fatal injuries, any losses, costs, and damages incurred as a result of Purchaser's operation of this item.

Purchaser is solely responsible when permitting other riders to ride this item, and assumes all responsibility in event of damages, injuries or fatal injuries etc. Purchaser is responsible for understanding and obeying all local and state laws for operation of this product. Once purchaser submits payment,

This will serve as purchaser agreement to release the seller of any and all responsibilities of the item such as stated above.

By purchasing, you acknowledge that you have read and understood, and you agree, to the terms and conditions of this Agreement, and you

represent that you are of legal age (age 18 or older) to enter this Agreement and become bound by its term.

While all care is taken, any errors and omissions in the item details are unintentional. Therefore, ORION cannot be held liable for any errors or omissions on these adverts.

